

WDA

Water cooled chillers



WDA water chillers are efficient, low-noise products designed for medium to large applications. They are suitable for generating chilled water at temperatures in the region of 7°C, commonly used in applications with fan coils and/or air handling units. The use of tandem scroll compressors results in high efficiencies (especially at part loads) and low noise levels, making them suitable for use in many applications. Differing versions and a wide range of accessories, enable the optimal solution to be selected.

Versions

- STD** Cooling only version.
- EV** Condenserless version.
- BT** Cooling only version for low user water temperature.
- RP** Cooling only version with partial heat recovery.

WDA		039	045	050	060	070	080	090	110	120
Cooling capacity (EN14511) ⁽¹⁾	kW	43,7	49,9	59,3	67,2	75,0	88,5	100,8	112,0	126,5
Total input power (EN14511) ⁽¹⁾	kW	10,5	12,1	15,1	16,7	17,7	20,9	23,9	26,9	30,5
EER (EN14511) ⁽¹⁾	W/W	4,16	4,12	3,92	4,02	4,23	4,23	4,21	4,16	4,14
Power supply	V/Ph/Hz	400/3/50	400/3/50	400/3/50	400/3/50	400/3/50	400/3/50	400/3/50	400/3/50	400/3/50
Peak current	A	111,0	132,0	140,0	162,0	171,0	208,0	259,0	265,0	312,0
Maximum input current	A	32,0	42,0	44,0	53,0	62,0	68,0	74,0	80,0	88,5
Compressors / Circuits	n°/n°	2/1	2/1	2/1	2/1	2/1	2/1	2/1	2/1	2/1
Global warming potential (GWP)		2088	2088	2088	2088	2088	2088	2088	2088	2088
Refrigerant charge	kg	5,0	5,0	6,0	6,0	7,0	8,0	14,0	14,0	14,0
Equivalent CO ₂ charge	t	10,4	10,4	12,5	12,5	14,6	16,7	29,2	29,2	29,2
Sound power ⁽²⁾	dB(A)	82	82	83	84	84	85	86	87	87
Sound pressure ⁽³⁾	dB(A)	66	66	67	68	68	69	69	70	70

WDA		130	152	162	190	210	240	260	300	320
Cooling capacity (EN14511) ⁽¹⁾	kW	141,1	162,4	182,5	201,6	223,9	257,6	285,7	323,5	365,2
Total input power (EN14511) ⁽¹⁾	kW	34,0	38,7	43,4	47,8	53,8	60,9	68,0	77,4	86,7
EER (EN14511) ⁽¹⁾	W/W	4,15	4,19	4,20	4,21	4,16	4,23	4,20	4,18	4,21
Power supply	V/Ph/Hz	400/3/50	400/3/50	400/3/50	400/3/50	400/3/50	400/3/50	400/3/50	400/3/50	400/3/50
Peak current	A	320,5	358,5	375,4	333,0	345,0	400,5	417,5	472,4	506,2
Maximum input current	A	97,0	113,9	130,8	148,0	160,0	177,0	194,0	227,8	261,6
Compressors / Circuits	n°/n°	2/1	2/1	2/1	4/2	4/2	4/2	4/2	4/2	4/2
Global warming potential (GWP)		2088	2088	2088	2088	2088	2088	2088	2088	2088
Refrigerant charge	kg	14,0	18,0	18,0	30,0	30,0	34,0	34,0	36,0	36,0
Equivalent CO ₂ charge	t	29,2	37,6	37,6	62,6	62,6	71,0	71,0	75,2	75,2
Sound power ⁽²⁾	dB(A)	88	88	88	89	91	91	91	93	93
Sound pressure ⁽³⁾	dB(A)	71	71	71	72	74	74	74	76	76

Performances are referred to the following conditions:

(1) Cooling: Evaporator water temp. 12/7°C condenser water temp. 30/35°C.

(2) Sound power level in accordance with ISO 3744 (LS-Version).

(3) Sound pressure level at 1 mt from the unit in free field conditions in accordance with ISO 3744 (LS-Version).

WDA/EV		039	045	050	060	070	080	090	110	120
Cooling capacity ⁽⁴⁾	kW	38,8	44,3	52,4	59,3	66,0	78,9	90,4	99,7	112,8
Total input power ⁽⁴⁾	kW	13,2	15,3	19,4	21,1	22,4	25,9	29,6	33,4	37,7
Water flow	m ³ h	6,7	7,6	9,0	10,2	11,3	13,5	15,5	17,1	19,4
Peak current	A	111,0	132,0	140,0	162,0	171,0	208,0	259,0	265,0	312,0
Max input current	A	32,0	42,0	44,0	53,0	62,0	68,0	74,0	80,0	88,5
Power supply	V/Ph/Hz	400/3/50	400/3/50	400/3/50	400/3/50	400/3/50	400/3/50	400/3/50	400/3/50	400/3/50
Compressors / Circuits	n°	2/1	2/1	2/1	2/1	2/1	2/1	2/1	2/1	2/1
Sound power ⁽²⁾	dB(A)	74	74	75	76	76	77	77	78	78
Sound pressure ⁽³⁾	dB(A)	46	46	47	48	48	49	49	50	50

WDA/EV		130	152	162	190	210	240	260	300	320
Cooling capacity ⁽⁴⁾	kW	125,8	145,0	162,6	178,3	197,8	221,4	245,8	277,5	314,0
Total input power ⁽⁴⁾	kW	42,2	48,0	53,9	59,2	66,5	76,3	85,1	96,9	108,6
Water flow	m ³ h	21,6	24,9	27,9	30,6	33,9	38,0	42,2	47,6	53,9
Peak current	A	320,5	358,5	375,4	333,0	345,0	400,5	417,5	472,4	506,2
Max input current	A	97,0	113,9	130,8	148,0	160,0	177,0	194,0	227,8	261,6
Power supply	V/Ph/Hz	400/3/50	400/3/50	400/3/50	400/3/50	400/3/50	400/3/50	400/3/50	400/3/50	400/3/50
Compressors / Circuits	n°	2/1	2/1	2/1	4/2	4/2	4/2	4/2	4/2	4/2
Sound power ⁽²⁾	dB(A)	79	79	79	80	82	82	82	84	84
Sound pressure ⁽³⁾	dB(A)	51	51	51	52	54	54	54	56	56

Performances are referred to the following conditions:

(4) For EV version: condensing temperature 50 °C, water temperature in/out 12/7 °C.

(2) Sound power level in accordance with ISO 3744. (LS versions).

(3) Sound pressure level at 1 mt from the unit in free field conditions in accordance with ISO 3744 (LS versions)

Frame

All WDA units are made from hot-galvanised sheet steel, painted with polyurethane powder enamel and stoved at 180°C to provide maximum protection against corrosion. The frame is self-supporting with removable panels. All screws and rivets used are made from stainless steel. The standard colour of the units is RAL 9018.

Refrigerant circuit

The refrigerant utilised is R410A. The refrigerant circuit is assembled using internationally recognised brand name components with all brazing and welding being performed in accordance with ISO 97/23. Each refrigerant circuit is totally independent from the other. Failure of one circuit does not influence the other circuit. The refrigerant circuit includes: sight glass, filter drier, reversing valve (for reversible version only), one way valve (for reversible version only), liquid receiver (for reversible version only), Schraeder valves for maintenance and control and pressure safety device (for compliance with PED regulations).

Also available is an electronic expansion valve with electronic control which optimises the efficiency in part load conditions (option).

Compressors

The compressors utilised are scroll type. All compressors are fitted with a crankcase heater and each compressor has a klixon embedded in the motor winding for thermal overload protection. The crankcase heater is always energised when the compressor is in stand-by. Access to the compressors is through the front and side panels. The compressors used are all in tandem configuration. This results in much higher efficiencies at part loads compared to units with independent refrigerant circuits.

Condensers

The condensers are braze welded, plate type heat exchangers, manufactured from AISI 316 stainless steel. Utilisation of this type of exchanger results in a massive reduction of the refrigerant charge of the unit compared to the traditional shell-in-tube type. A further advantage is a reduction in the overall dimensions of the unit and an increase in efficiency of the refrigerant cycle in partial loads. From size 039 to size 162 they have a single water side circuit, from size 144 upwards they are double circuit "cross flow" type.

Evaporators

The evaporators are braze welded, plate type heat exchangers, manufactured from AISI 316 stainless steel. From size 039 to size 162 they have a single water side circuit, from size 190 upwards they are double circuit "cross flow" type.

All units are supplied with a sub-cooler to enhance the performance of the refrigerant cycle. The evaporators are factory insulated with flexible close cell material and are supplied with a temperature sensor as antifreeze protection.

Microprocessors

All WDA units are supplied as standard with microprocessor controls. The microprocessor controls the following functions: control of the water temperature, antifreeze protection, compressor timing, compressor automatic starting sequence, alarm reset, volt free contact for remote general alarm, alarms and operation LED's. If required (available as an option), the microprocessor can be configured in order for it to connect to a site BMS system thus enabling remote control and management. The Hidros technical

department can discuss and evaluate, in conjunction with the customer, solutions using MODBUS protocols.

Electrics enclosure

The enclosure is manufactured in order to comply with the requirements of the electromagnetic compatibility standards CEE 73/23 and 89/336. Access to the enclosure is achieved by removing the front panel of the unit. The following components are supplied as standard on all units: main switch, thermal overloads (protection of pumps and fans), compressor fuses, control circuit automatic breakers, compressor contactors, fan contactors and pump contactors. The terminal board has volt free contacts for remote ON-OFF, Summer/Winter change over (reversible versions only) and general alarm. For all three phase units, a sequence relay that disables the power supply in the event that the phase sequence is incorrect (scroll compressors can be damaged if they rotate in the wrong direction), is fitted as standard.

Control and protection devices

All units are supplied with the following control and protection devices: Return water temperature sensor installed on the return water line from the building (12°C), antifreeze protection sensor installed on the outlet water temperature (7°C), high pressure switch with manual reset, low pressure switch with automatic reset, high pressure safety valve, compressor thermal overload protection, fans thermal overload protection and flow switch.

Versions

Cooling only version for low user water temperature (BT)

This version is supplied with a specific refrigerant circuit that allows the operation of the unit with user water outlet conditions between +4°C and -5°C.

Condenserless versions (EV)

This version includes a microprocessor control to manage both the compressor timings and alarms. It is designed to operate with refrigerant R410A but is supplied with a holding charge of nitrogen.

Partial heat recovery (RP)

This version is supplied with an auxiliary heat exchanger fitted in series with the unit condenser thereby enabling it to produce hot water when the unit is operating in cooling mode.

WDA - WDA/EV		039-080	090-162	190-320
Main switch	—	●	●	●
Flow switch	—	●	●	●
LS low noise versions	LS01	○	○	○
Hydraulic kit S1NT with only pump source circuit	S1NT	○	○	○
Partial heat recovery	RP00	○	○	○
Rubber anti-vibration mountings	KAVG	○	○	○
Spring anti-vibration mountings	KAVM	○	○	○
Electronic soft starter	DSSE	○	○	○
Refrigerant circuit pressure gauges	MAML	○	○	○
Liquid line solenoid valve	VSLI	○	○	○
Pressostatic valve kit for cooling versions	VPSF	○	○	○
Remote control panel	PCRL	○	○	○
Serial interface card RS485	INSE	○	○	○
Source 4÷20 mA modulating valve	V2M0	○	○	○

● Standard, ○ Optional, — Not available.

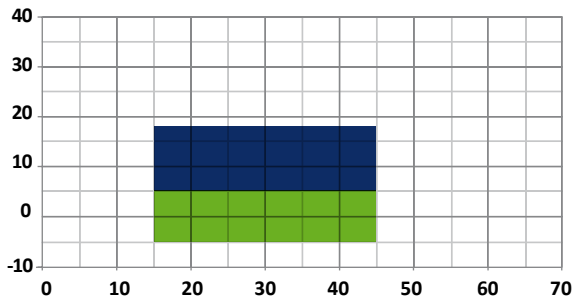

● All versions

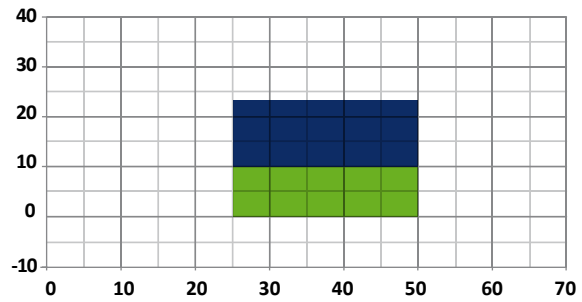

● Only BT version (working mode with glycol)

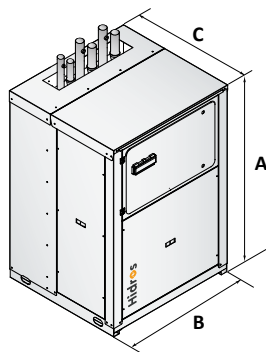

WDA 039 ÷ 162

Mod.	A (mm)	B (mm)	C (mm)	kg
039	1566	1101	1005	430
045	1566	1101	1005	440
050	1566	1101	1005	460
060	1566	1101	1005	470
070	1566	1101	1005	480
080	1566	1101	1005	490
090	1986	1101	1255	580
110	1986	1101	1255	600
120	1986	1101	1255	630
130	1986	1101	1255	650
152	1986	1101	1255	730
162	1986	1101	1255	760

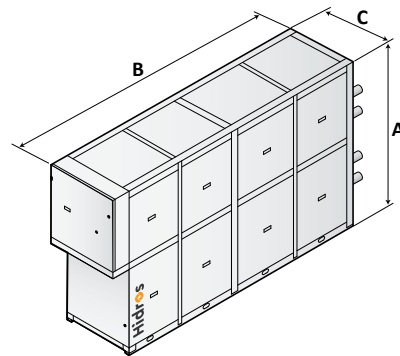

WDA 190 ÷ 320

Mod.	A (mm)	B (mm)	C (mm)	kg
190	1900	3120	800	1170
210	1900	3120	800	1210
240	1900	3120	800	1270
260	1900	3120	800	1320
300	1900	3120	800	1390
320	1900	3120	800	1430