

WHK

Super-high temperature water to water heat pumps

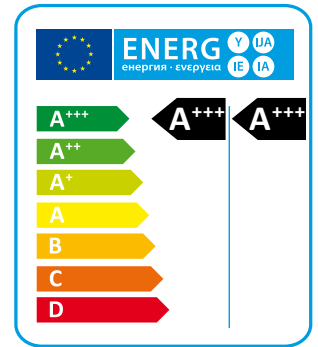

WHK heat pumps are particularly suitable for applications that use source energy at medium or high temperatures. These units have been designed to produce water at high or very high temperature for applications where it is necessary to have maximum efficiency in heating. The units are available in heating only mode and can produce water up to 78°C (HT version). A wide range of accessories allows you to choose the optimal solution.

Versions

- HH** Standard, heating only.
- LT** Low source/user temperature.
- HT** High source/user temperature.
- LS** Low noise.
- XL** Super low noise.
- P2U** 2 pipe systems without domestic hot water production.

| WHK LT/XL/HH - P2U | | 302 | 402 | 602 | 702 | 902 | 1202 | 1402 | 1804 | 2304 | 2604 |
|--|---------|----------|----------|----------|----------|----------|----------|----------|----------|----------|----------|
| Heating capacity (EN14511) ⁽¹⁾ | kW | 38,8 | 46,0 | 58,4 | 70,3 | 88,4 | 109,9 | 136,5 | 176,9 | 219,5 | 273,2 |
| Input power (EN14511) ⁽¹⁾ | kW | 8,2 | 9,4 | 11,8 | 14,8 | 18,8 | 23,1 | 27,9 | 37,2 | 45,7 | 55,3 |
| COP (EN14511) ⁽¹⁾ | W/W | 4,73 | 4,85 | 4,93 | 4,76 | 4,70 | 4,75 | 4,88 | 4,75 | 4,80 | 4,94 |
| Energy Class in low temperature ⁽²⁾ | | A+++ | A+++ | A+++ | A+++ | A+++ | A+++ | A+++ | A+++ | A+++ | A+++ |
| SCOP low temperature ⁽²⁾ | kWh/kWh | 4,85 | 5,00 | 5,16 | 5,00 | 5,08 | 5,17 | 5,36 | 5,29 | 5,38 | 5,56 |
| η _{s,h} low temperature ⁽²⁾ | % | 185,9 | 192,1 | 198,2 | 191,8 | 195,3 | 198,9 | 206,3 | 203,4 | 207,0 | 214,4 |
| Energy Class in medium temperature ⁽²⁾ | | A++ | A++ | A++ | A++ | A++ | A++ | A++ | A++ | A++ | A++ |
| SCOP medium temperature ⁽²⁾ | kWh/kWh | 4,07 | 4,19 | 4,28 | 4,18 | 4,16 | 4,22 | 4,35 | 4,27 | 4,34 | 4,47 |
| η _{s,h} medium temperature ⁽²⁾ | % | 154,8 | 159,6 | 163,0 | 159,0 | 158,3 | 160,9 | 165,9 | 162,8 | 165,6 | 170,7 |
| Power supply | V/Ph/Hz | 400/3/50 | 400/3/50 | 400/3/50 | 400/3/50 | 400/3/50 | 400/3/50 | 400/3/50 | 400/3/50 | 400/3/50 | 400/3/50 |
| Maximum input current | A | 128,7 | 137,6 | 168,0 | 209,0 | 266,0 | 324,0 | 372,5 | 348,0 | 428,0 | 497,5 |
| Peak current | A | 35,4 | 39,2 | 56,0 | 70,0 | 82,0 | 104,0 | 125,0 | 164,0 | 208,0 | 250,0 |
| Compressors / Circuits | n°/n° | 2/1 | 2/1 | 2/1 | 2/1 | 2/1 | 2/1 | 2/1 | 4/2 | 4/2 | 4/2 |
| Capacity steps | n° | 2 | 2 | 2 | 2 | 2 | 2 | 2 | 4 | 4 | 4 |
| Refrigerant | | R134a | R134a | R134a | R134a | R134a | R134a | R134a | R134a | R134a | R134a |
| Global warming potential (GWP) | | 1430 | 1430 | 1430 | 1430 | 1430 | 1430 | 1430 | 1430 | 1430 | 1430 |
| Refrigerant charge | kg | 2,0 | 2,0 | 3,0 | 3,0 | 4,0 | 5,0 | 6,0 | 8,5 | 10,5 | 13,0 |
| Equivalent CO ₂ charge | t | 2,9 | 2,9 | 4,3 | 4,3 | 5,7 | 7,2 | 8,6 | 12,2 | 15,0 | 18,6 |
| Sound power LS version ⁽³⁾ | dB(A) | -- | -- | -- | -- | -- | -- | -- | 88 | 89 | 91 |
| Sound pressure LS version ⁽⁴⁾ | dB(A) | -- | -- | -- | -- | -- | -- | -- | 72 | 73 | 75 |
| Sound power XL version ⁽³⁾ | dB(A) | 65 | 65 | 70 | 73 | 74 | 76 | 78 | -- | -- | -- |
| Sound pressure XL version ⁽⁴⁾ | dB(A) | 49 | 49 | 54 | 57 | 58 | 60 | 62 | -- | -- | -- |

| WHK HT/XL/HH - P2U | | 302 | 402 | 602 | 702 | 902 | 1202 | 1402 | 1804 | 2304 | 2604 |
|--|---------|----------|----------|----------|----------|----------|----------|----------|----------|----------|----------|
| Heating capacity (EN14511) ⁽¹⁾ | kW | 37,6 | 43,6 | 64,1 | 75,1 | 97,8 | 121,7 | 150,5 | 195,6 | 243,9 | 301,2 |
| Input power (EN14511) ⁽¹⁾ | kW | 6,7 | 7,5 | 11,1 | 13,7 | 17,6 | 21,7 | 26,2 | 35,0 | 43,1 | 52,2 |
| COP (EN14511) ⁽¹⁾ | W/W | 5,65 | 5,83 | 5,79 | 5,48 | 5,56 | 5,62 | 5,74 | 5,59 | 5,65 | 5,77 |
| Energy Class in low temperature ⁽²⁾ | | A+++ | A+++ | A+++ | A+++ | A+++ | A+++ | A+++ | A+++ | A+++ | A+++ |
| SCOP low temperature ⁽²⁾ | kWh/kWh | 5,71 | 5,83 | 5,91 | 5,81 | 5,85 | 5,94 | 6,09 | 5,95 | 6,01 | 6,20 |
| η _{s,h} low temperature ⁽²⁾ | % | 220,2 | 225,3 | 228,2 | 224,5 | 226,0 | 229,4 | 235,6 | 230 | 232,4 | 239,9 |
| Energy Class in medium temperature ⁽²⁾ | | A++ | A++ | A++ | A++ | A++ | A++ | A++ | A++ | A++ | A++ |
| SCOP medium temperature ⁽²⁾ | kWh/kWh | 4,62 | 4,73 | 4,78 | 4,76 | 4,67 | 4,74 | 4,85 | 4,73 | 4,79 | 4,91 |
| η _{s,h} medium temperature ⁽²⁾ | % | 176,9 | 181,1 | 183,2 | 182,2 | 178,7 | 181,5 | 186,1 | 181 | 183,6 | 188,3 |
| Power supply | V/Ph/Hz | 400/3/50 | 400/3/50 | 400/3/50 | 400/3/50 | 400/3/50 | 400/3/50 | 400/3/50 | 400/3/50 | 400/3/50 | 400/3/50 |
| Maximum input current | A | 111,4 | 128,7 | 167,1 | 208,3 | 267,9 | 324,8 | 372,9 | 353,7 | 430,4 | 498,7 |
| Peak current | A | 32,8 | 35,4 | 54,2 | 68,6 | 85,8 | 105,6 | 125,8 | 171,6 | 211,2 | 251,6 |
| Compressors / Circuits | n°/n° | 2/1 | 2/1 | 2/1 | 2/1 | 2/1 | 2/1 | 2/1 | 4/2 | 4/2 | 4/2 |
| Capacity steps | n° | 2 | 2 | 2 | 2 | 2 | 2 | 2 | 4 | 4 | 4 |
| Refrigerant | | R134a | R134a | R134a | R134a | R134a | R134a | R134a | R134a | R134a | R134a |
| Global warming potential (GWP) | | 1430 | 1430 | 1430 | 1430 | 1430 | 1430 | 1430 | 1430 | 1430 | 1430 |
| Refrigerant charge | kg | 4,0 | 4,0 | 5,0 | 6,0 | 8,0 | 10,0 | 10,0 | 21,0 | 26,0 | 33,0 |
| Equivalent CO ₂ charge | t | 5,7 | 5,7 | 7,2 | 8,6 | 11,4 | 14,3 | 14,3 | 30,0 | 37,2 | 47,2 |
| Sound power LS version ⁽³⁾ | dB(A) | -- | -- | -- | -- | -- | -- | -- | 88 | 89 | 91 |
| Sound pressure LS version ⁽⁴⁾ | dB(A) | -- | -- | -- | -- | -- | -- | -- | 72 | 73 | 75 |
| Sound power XL version ⁽³⁾ | dB(A) | 65 | 65 | 70 | 73 | 74 | 76 | 78 | -- | -- | -- |
| Sound pressure XL version ⁽⁴⁾ | dB(A) | 49 | 49 | 54 | 57 | 58 | 60 | 62 | -- | -- | -- |

Performances are referred to the following conditions:

(1) Heating: user water temperature 30/35°C, source water temperature 10/7°C.

(2) Average conditions, variable - Reg EU 811/2013

(3) Sound power level in accordance with ISO 3744.

(4) Sound pressure level at 1 mt from the unit in free field conditions in accordance with ISO 3744.

Frame

All units are made from hot-galvanised sheet steel, painted with polyurethane powder enamel and stoved at 180°C to provide maximum protection against corrosion. The frame is self-supporting with removable panels. All screws and rivets used are made from stainless steel. The standard colour of the units is RAL 9018.

Refrigerant circuit

The refrigerant utilised is R134a. The refrigerant circuit is assembled using internationally recognised brand name components with all brazing and welding being performed in accordance with ISO 97/23. Each refrigerant circuit is totally independent from the other with the result that any fault or alarm condition on one circuit does not influence the other.

The refrigerant circuit includes: sight glass, filter drier, thermal expansion valve with external equalizer, Schrader valves for maintenance and control and pressure safety device (for compliance with PED regulations).

Compressors

The compressors used are a high performance scroll type that incorporates a special scroll design which enhances the efficiency of the refrigerant cycle when the source temperature is low. The compressors are all supplied with a crankcase heater and thermal overload protection by a klixon embedded in the motor winding. They are mounted in a separate enclosure thus enabling them to be maintained even if the unit is operating. Access to this enclosure is via the front panel of the unit. The crankcase heater is always powered when the compressor is in stand-by.

Source heat exchanger

Source heat exchanger are braze-welded plates and are made of stainless steel AISI 316.

The use of this type of exchangers greatly reduces the refrigerant charge of the unit compared to the conventional shell and tube evaporators, and increases the efficiency of the refrigerant loads. The heat exchangers are factory insulated with flexible close cell material and are protected by a temperature sensor used as antifreeze protection kit.

User exchanger

The user side heat exchanger is a braze welded, plate type heat exchanger, manufactured from AISI 316 stainless steel.

All units are supplied with a sub-cooler to enhance the performance of the refrigerant cycle. The user heat exchangers are factory insulated with flexible close cell material.

Microprocessors

All units are supplied as standard with microprocessor controls. The microprocessor controls the following functions:

control of the water temperature, antifreeze protection, compressor timing, compressor automatic starting sequence, alarm reset, volt free contact for remote general alarm, alarms and operation LED's. If required (available as an option), the microprocessor can be configured in order for it to connect to a site BMS system thus enabling remote control and management. The technical department can discuss and evaluate, in conjunction with the customer, solutions using MODBUS protocols.

Electric enclosure

The enclosure is manufactured in order to comply with the requirements of the electromagnetic compatibility standards CEE EN60204. Access to the enclosure is achieved by removing the

front panel of the unit. The following components are supplied as standard on all units: main switch, thermal overloads (protection of pumps and fans), compressor fuses, control circuit automatic breakers, compressor contactors, fan contactors and pump contactors. The terminal board has volt free contacts for remote ON-OFF, Summer/Winter change over (reversible type only) and general alarm. For all three phase units, a sequence relay that disables the power supply in the event that the phase sequence is incorrect (scroll compressors can be damaged if they rotate in the wrong direction), is fitted as standard.

Control and protection devices

All units are supplied with the following control and protection devices: Return and supply user heat exchanger sensors, return and supply source heat exchanger sensors, high pressure switch with manual reset, low pressure switch with automatic reset, high pressure safety valve, compressor thermal overload protection, pump thermal overload protection (when present), source heat exchanger flow switch.

Versions

WHK/HH

These units have been designed to produce water at high or very high temperature by using a source water temperature of 12°C with possibility to produce hot water up to 70°C or more.

WHK/HH/HT

This version is equipped with special compressors that allow the cooling circuit to manage high source water temperature, up to 45°C, with the consequent possibility of producing very high water temperatures on the user side up to 78°C.

WHK/HH/LT

This version is equipped with special compressors that allow the cooling circuit to manage medium source water temperature, up to 20°C, with the consequent possibility of producing very high water temperatures on the user side up to 70°C.

Version LS

This version includes the complete acoustic insulation of the unit with compressor jackets and insulating material made with high density media and the interposition of heavy bitumen layer.

Super low noise version XL

All units in XL versions are supplied, as standard, with the latest 'Floating Frame' technology that completely isolates the compressors from the main casing, thereby eliminating vibration and noise from this source. The 'Floating Frame' is a special vibration and acoustic damping system that consists of a base plate and acoustic enclosure that houses the compressors. The base plate is separated from the supporting frame of the unit by soft steel springs that have a high damping power. Within the enclosure, the compressors are mounted on rubber shock absorbers on the floating base plate. The enclosure is manufactured from galvanized steel sandwich panels that have a micro-perforated inner skin and a core of 30 mm thick, high density (25 kg/m³). The entire arrangement provides a double damping system and acoustic attenuation. The compressor refrigerant pipes are connected to the refrigerant circuit through "anaconda" flexible connections. Flexible connections are also used on the water pipework within the unit. The combination of these systems results in an overall noise reduction in the region of 6-8 dB(A).

| WHK | | 302 | 402 | 602 | 702 | 902 | 1202 | 1402 | 1804 | 2304 | 2604 |
|--|-------|-----|-----|-----|-----|-----|------|------|------|------|------|
| XL Super low noise version | XL00 | ● | ● | ● | ● | ● | ● | ● | - | - | - |
| LS low noise version [-4dB(A) of STD] | LS00 | - | - | - | - | - | - | - | ● | ● | ● |
| Electronic Soft starter | DSSE | ○ | ○ | ○ | ○ | ○ | ○ | ○ | ○ | ○ | ○ |
| Rubber anti-vibration mountings | KAVG | ○ | ○ | ○ | ○ | ○ | ○ | ○ | ○ | ○ | ○ |
| Spring anti-vibration mountings | KAVM | ○ | ○ | ○ | ○ | ○ | ○ | ○ | ○ | ○ | ○ |
| Refrigerant circuit pressure gauges | MAML | ○ | ○ | ○ | ○ | ○ | ○ | ○ | ○ | ○ | ○ |
| Liquid line solenoid valve | VSLI | ○ | ○ | ○ | ○ | ○ | ○ | ○ | ○ | ○ | ○ |
| Remote control panel | PCRL | ○ | ○ | ○ | ○ | ○ | ○ | ○ | ○ | ○ | ○ |
| Serial interface card RS485 with MODBUS protocol | INSE | ● | ● | ● | ● | ● | ● | ● | ● | ● | ● |
| 2 way modulating valve - source | V2M0 | ○ | ○ | ○ | ○ | ○ | ○ | ○ | ○ | ○ | ○ |
| Electronic thermostatic valve | VTEE | ○ | ○ | ○ | ○ | ○ | ○ | ○ | ○ | ○ | ○ |
| Hydraulic kit with 1 pump - user circuit | A1NTU | - | - | - | - | - | - | - | ○ | ○ | ○ |
| Hydraulic kit with 1 pump - source circuit | A1NTS | - | - | - | - | - | - | - | ○ | ○ | ○ |
| Hydraulic kit with 1 pump - recovery circuit | A1NTR | - | - | - | - | - | - | - | ○ | ○ | ○ |
| Hydraulic kit with 2 pumps - user circuit | A2NTU | - | - | - | - | - | - | - | ○ | ○ | ○ |
| Hydraulic kit with 2 pumps - source circuit | A2NTS | - | - | - | - | - | - | - | ○ | ○ | ○ |
| Hydraulic kit with 2 pumps - recovery circuit | A2NTR | - | - | - | - | - | - | - | ○ | ○ | ○ |

● Standard, ○ Optional, - Not available.

Operation limits

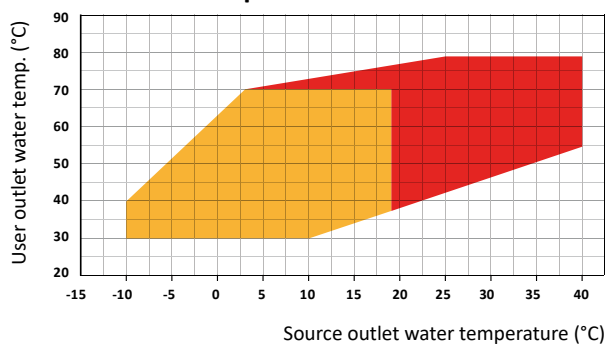

● Heating
● Heating with HT version

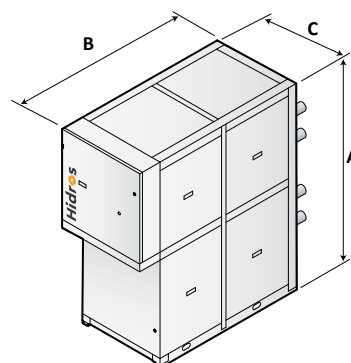
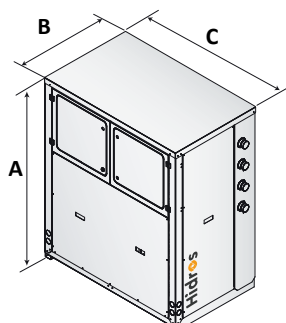

| Mod. | A (mm) | B (mm) | C (mm) | kg |
|------|--------|--------|--------|-----|
| 302 | 1600 | 800 | 1150 | 660 |
| 402 | 1600 | 800 | 1150 | 680 |
| 602 | 1600 | 800 | 1150 | 700 |
| 702 | 1600 | 800 | 1150 | 730 |
| 902 | 1600 | 800 | 1150 | 740 |
| 1202 | 1600 | 800 | 1150 | 760 |
| 1402 | 1600 | 800 | 1150 | 790 |

| Mod. | A (mm) | B (mm) | C (mm) | kg |
|------|--------|--------|--------|------|
| 1804 | 1900 | 3120 | 800 | 1320 |
| 2304 | 1900 | 3120 | 800 | 1390 |
| 2604 | 1900 | 3120 | 800 | 1430 |