

# WZT

## High efficiency air to water split system heat pumps with E.V.I. compressors

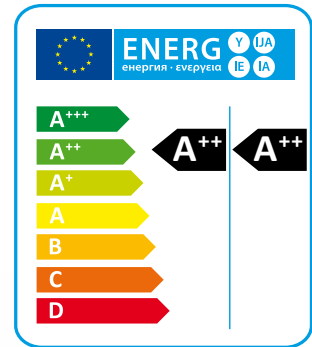

The air source high efficiency heat pumps WZT series, in the NN configuration, are particularly suitable for those applications where it is necessary to have maximum efficiency in heating mode and a noise level extremely low and, for this purpose, are provided in two sections, linked together by refrigerant lines, installing the compressor in the internal section. The units have been designed specifically to have the best possible efficiency, they may operate down to ambient temperatures of -20°C and produce hot water up to 65°C. The units are available in 2-pipe (P2S, P2U), version 2 + 2 pipe (P4S), and in version 4 pipe (P4U).

The units P2U are not able to produce sanitary hot water, the P2S versions are able to produce domestic hot water through the activation of an external 3-way valve (not supplied), while P4S versions and P4U too are able to produce hot water regardless of the mode unit is operating, through the activation of a specific refrigerating circuit. All models are equipped with reverse cycle valve for winter defrost mode, RV versions are also able to produce cold water in summer (not available for HH version).

The noise level is extremely contained thanks to the use of a special floating system vibration damping that enables a reduction in terms of noise about 6-8 db (A) of compressors side and the fans in the combination with the specific number of turns extremely low (about 450 rpm).

### Versions

- HH** Heating only.
- RV** Reversible heating/cooling.
- HE** High efficiency, EC fans.
- NN** Ultra low noise.
- P2U** 2 pipe systems without domestic hot water production.
- P2S** 2 pipe systems with domestic hot water production by external 3 way valve.
- P4U** 4 pipe systems heating/cooling.
- P4S** 2+2 pipe systems with domestic hot water production.

## Heating only version (HH)

HE/NN/HH		252	302	452	502	602	752	852	1002	1202
Heating capacity (EN14511) <sup>(1) *</sup>	kW	24,1	29,9	44,0	53,7	59,7	69,5	80,5	87,8	101,8
Total input power (EN14511) <sup>(1) *</sup>	kW	5,0	6,4	9,0	11,9	12,5	15,1	17,4	19,0	22,9
COP (EN14511) <sup>(1) *</sup>	W/W	4,86	4,66	4,91	4,50	4,78	4,61	4,63	4,62	4,44
Energy Class in low temperature <sup>(2) *</sup>		A++	A++	A++	A++	A++	A++	A++	A++	A++
SCOP low temperature <sup>(2) *</sup>	kWh/kWh	4,36	4,22	4,17	3,87	4,23	4,19	4,12	4,16	4,06
η <sub>s,h</sub> low temperature <sup>(2) *</sup>	%	171,4	165,6	163,8	151,6	166,1	164,6	161,9	163,3	159,3
Energy Class in medium temperature <sup>(2) *</sup>		A++	A++	A++	A++	A++	A++	A++	A++	A++
SCOP medium temperature <sup>(2) *</sup>	kWh/kWh	3,51	3,49	3,45	3,31	3,49	3,45	3,43	3,43	3,42
η <sub>s,h</sub> medium temperature <sup>(2) *</sup>	%	137,50	136,7	134,8	129,4	136,6	134,9	134,1	134,1	133,7
Nominal waterflow	l/h	4150	5148	7573	9228	10267	11951	13853	15095	17510
Power supply	V/Ph/Hz	400/3/50	400/3/50	400/3/50	400/3/50	400/3/50	400/3/50	400/3/50	400/3/50	400/3/50
Max input current standard unit	A	18,7	22,3	32,5	38,3	43,1	53,2	66,2	68,0	76,8
Peak current standard unit	A	61,1	81,4	117,5	147,7	140,2	167,2	207,7	209,0	209,0
Outdoor unit with single heat exchanger max airflow	m <sup>3</sup> /h	9000	9000	10000	16000	21000	21000	32000	32000	32000
Compressors / Circuits	n°/n°	2/1	2/1	2/1	2/1	2/1	2/1	2/1	2/1	2/1
Global warming potential (GWP)		2088	2088	2088	2088	2088	2088	2088	2088	2088
Refrigerant charge <sup>(7)</sup>	kg	9,0	9,0	14,5	23,0	23,0	27,0	36,0	36,0	36,0
Equivalent CO <sub>2</sub> charge	t	18,79	18,79	30,27	48,02	48,02	56,37	75,16	75,16	75,16
Sound power indoor unit <sup>(4)</sup>	dB (A)	67	68	69	69	69	69	71	71	71
Sound pressure indoor unit <sup>(5)</sup>	dB (A)	51	52	53	53	53	53	54	54	54
Sound power outdoor unit - single heat exchanger <sup>(4)</sup>	dB (A)	69	69	70	--	--	--	--	--	--
Sound pressure outdoor unit - single heat exchanger <sup>(6)</sup>	dB (A)	37	37	38	--	--	--	--	--	--
Sound power outdoor unit - double heat exchanger <sup>(4)</sup>	dB (A)	--	--	--	70	70	70	72	72	72
Sound pressure outdoor unit - double heat exchanger <sup>(6)</sup>	dB (A)	--	--	--	38	38	38	40	40	40

## Reversible heating/cooling version (RV)

HE/NN/RV		252	302	452	502	602	752	852	1002	1202
Heating capacity (EN14511) <sup>(1) *</sup>	kW	24,1	29,9	44,0	53,7	59,7	69,5	80,5	87,8	101,8
Total input power (EN14511) <sup>(1) *</sup>	kW	5,0	6,4	9,0	11,9	12,5	15,1	17,4	19,0	22,9
COP (EN14511) <sup>(1) *</sup>	W/W	4,86	4,66	4,91	4,50	4,78	4,61	4,63	4,62	4,44
Energy Class in low temperature <sup>(2) *</sup>		A++	A++	A++	A++	A++	A++	A++	A++	A++
SCOP low temperature <sup>(2) *</sup>	kWh/kWh	4,36	4,22	4,17	3,87	4,23	4,19	4,12	4,16	4,06
η <sub>s,h</sub> low temperature <sup>(2) *</sup>	%	171,4	165,6	163,8	151,6	166,1	164,6	161,9	163,3	159,3
Energy Class in medium temperature <sup>(2) *</sup>		A++	A++	A++	A++	A++	A++	A++	A++	A++
SCOP medium temperature <sup>(2) *</sup>	kWh/kWh	3,51	3,49	3,45	3,31	3,49	3,45	3,43	3,43	3,42
η <sub>s,h</sub> medium temperature <sup>(2) *</sup>	%	137,50	136,7	134,8	129,4	136,6	134,9	134,1	134,1	133,7
η <sub>s,h</sub> high temperature <sup>(2) *</sup>	l/h	4150	5148	7573	9228	10267	11951	13853	15095	17510
Cooling capacity (EN14511) <sup>(3) *</sup>	kW	19,6	24,1	34,8	42,7	49,7	57,6	66,0	73,1	84,4
Total input power (EN14511) <sup>(3) *</sup>	kW	6,7	9,3	11,5	14,8	16,6	20,5	23,0	24,8	30,6
EER (EN14511) <sup>(3) *</sup>	W/W	2,93	2,59	3,04	2,89	3,00	2,81	2,87	2,95	2,76
Power supply	V/Ph/Hz	400/3/50	400/3/50	400/3/50	400/3/50	400/3/50	400/3/50	400/3/50	400/3/50	400/3/50
Max input current standard unit	A	18,7	22,3	32,5	38,3	43,1	53,2	66,2	68,0	76,8
Peak current standard unit	A	61,1	81,4	117,5	147,7	140,2	167,2	207,7	209,0	209,0
Outdoor unit with single heat exchanger max airflow	m <sup>3</sup> /h	9000	9000	10000	16000	21000	21000	32000	32000	32000
Compressors / Circuits	n°/n°	2/1	2/1	2/1	2/1	2/1	2/1	2/1	2/1	2/1
Global warming potential (GWP)		2088	2088	2088	2088	2088	2088	2088	2088	2088
Refrigerant charge <sup>(7)</sup>	kg	9,0	9,0	14,5	23,0	23,0	27,0	36,0	36,0	36,0
Equivalent CO <sub>2</sub> charge	t	18,79	18,79	30,27	48,02	48,02	56,37	75,16	75,16	75,16
Sound power indoor unit <sup>(4)</sup>	dB (A)	67	68	69	69	69	69	71	71	71
Sound pressure indoor unit <sup>(5)</sup>	dB (A)	51	52	53	53	53	53	54	54	54
Sound power outdoor unit - single heat exchanger <sup>(4)</sup>	dB (A)	69	69	70	--	--	--	--	--	--
Sound pressure outdoor unit - single heat exchanger <sup>(6)</sup>	dB (A)	37	37	38	--	--	--	--	--	--
Sound power outdoor unit - double heat exchanger <sup>(4)</sup>	dB (A)	--	--	--	70	70	70	72	72	72
Sound pressure outdoor unit - double heat exchanger <sup>(6)</sup>	dB (A)	--	--	--	38	38	38	40	40	40

Performances are referred to the following conditions:

(1) Heating: Ambient temperature 7°C DB, 6°C WB, water temperature 30/35°C.

(2) Average conditions, variable - Reg EU 811/2013

(3) Cooling: ambient temperature 35°C, water temperature 12/7°C (RV versions only).

(4) Sound power level in accordance with ISO 3744.

(5) Sound pressure level at 1 mt from the unit in free field conditions, in accordance with ISO 3744.

(6) Sound pressure level at 10 mt from the unit in free field conditions, in accordance with ISO 3744.

(7) Without refrigerant lines content

\* Data referred to outdoor unit with single heat exchanger.

## Frame

All WZT units are made from hot-galvanised sheet steel, painted with polyurethane powder enamel and stoved at 180°C to provide maximum protection against corrosion. The frame is self-supporting with removable panels. All screws and rivets used are made from stainless steel. The standard colour of the units is RAL 9018.

## Refrigerant circuit

The refrigerant utilised is R410A. The refrigerant circuit is assembled using internationally recognised brand name components with all brazing and welding being performed in accordance with ISO 97/23. The refrigerant circuit includes: sight glass, filter drier, two thermal expansion valves (one for cooling mode, one for heating mode) with external equalizer, 4 way reversing valve, check valves, liquid receiver, Schrader valves for maintenance and control, pressure safety device (for compliance with PED regulations). The circuit also includes an AISI316 stainless steel heat exchanger that is used as an economizer plus an additional expansion valve for refrigerant vapour injection.

## Compressors

Scroll compressors equipped with E.V.I. technology, a versatile method of improving system capacity and efficiency. E.V.I. stands for "Economised Vapour Injection." The technology involves injecting refrigerant vapour into the middle of the compression process, a procedure that significantly boosts capacity and efficiency. Each scroll compressor used in these units is similar to a two-stage compressor with built-in inter-stage cooling. The process begins when a portion of the condenser liquid is extracted and expanded through an expansion valve. The low temperature liquid/gas mixture produced is injected into a heat exchanger that operates as a sub cooler. Any liquid is evaporated and the vapour produced is superheated.

The superheated vapour is then injected into an intermediate port in the scroll compressor. This cold vapour reduces the temperature of the compressed gas thus enabling the compressor to raise the pressure to levels (and temperatures) beyond that possible with a single stage scroll. The additional sub cooling of the main volume of liquid refrigerant increases the evaporator capacity. This compressor technology generates a larger pressure ratio between condensing and evaporating pressures, with significant performance improvement. The compressors are connected in tandem, they are all supplied with a crankcase heater and thermal overload protection by a klixon embedded in the motor winding. They are mounted in a separate enclosure in order to be separated from the air stream thus enabling them to be maintained even if the unit is operating. Access to this enclosure is by the front panel of the unit. The crankcase heater is always powered when the compressor is in stand-by.

## Source Heat Exchanger

The source heat exchanger is made from 3/8" copper pipes and 0.1mm thick aluminium fins with the tubes being mechanically expanded into the aluminium fins in order to maximise heat transfer. Furthermore, the design guarantees a low air side pressure drop thus enabling the use of low rotation speed (and hence low noise) fans.

## User heat exchangers

The user heat exchanger is a braze welded, plate type heat exchanger, manufactured from AISI 316 stainless steel. Utilisation of this type of exchanger results in a massive reduction of the refrigerant charge of the unit compared to a traditional shell-in-tube type. A further advantage is a reduction in the overall dimensions of the unit.

The exchangers are factory insulated with flexible close cell material and can be fitted with an antifreeze heater (accessory). Each exchanger is fitted with a temperature sensor on the discharge water side for antifreeze protection.

## Fans

The fans are axial type with high performance aerofoil blades, the impeller is made of galvanized sheet galvanized, painted with polyurethane powder, to ensure a high protection in aggressive and severe environments. The impeller mounted directly on DC-brushless motor with external rotor, to ensure ideal cooling of the engine and a total absence of losses of the transmission. Impeller dynamically balanced in class 6.3 according to ISO 1940. Engine brushless-DC permanent magnet high efficiency electronic switching unit (driver) separate. Continuous speed variation with voltage signal 0-10 V, PFC integrated protection "burn out" (excessive drop in voltage), fully IP54 driver, serial interface with Modbus RTU communication protocol. The maximum rotation speed of the motor is 450 rpm to guarantee an extremely low noise level.

## Microprocessors

All units are supplied as standard with microprocessor controls. The microprocessor controls the following functions: control of the water temperature, antifreeze protection, compressor timing, compressor automatic starting sequence (For multiple compressors), alarm reset. The control panel is supplied with display showing all operational icons. The microprocessor is set for automatic defrost (when operating in severe ambient conditions) and for summer/winter change over. The control also manages the anti-legionella program, the integration with other heating sources (electric heaters, boilers, solar panels etc), the operation of a three port modulating valve (for diverting to DHW or heating) and both the heating circuit pump and the domestic hot water circuit pump. If required (available as an option), the microprocessor can be configured in order for it to connect to a site BMS system thus enabling remote control and management. The technical department can discuss and evaluate, in conjunction with the customer, solutions using MODBUS protocols.

## Electric enclosure

The enclosure is manufactured in order to comply with the requirements of the electromagnetic compatibility standards CEE EN60204. Access to the enclosure is achieved by removing the front panel of the unit. The following components are supplied as standard on all units: main switch, thermal overloads (protection of pumps and fans), compressor fuses, control circuit automatic breakers, compressor contactors, fan contactors and pump contactors.

The terminal board has volt free contacts for remote ON-OFF, Summer/Winter change over and general alarm. For all three

phase units, a sequence relay that disables the power supply in the event that the phase sequence is incorrect (scroll compressors can be damaged if they rotate in the wrong direction), is fitted as standard.

### Control and protection devices

All units are supplied with the following control and protection devices: Return user water temperature sensor, antifreeze protection sensor installed on the user outlet water temperature, return and supply, high pressure switch with manual reset, low

pressure switch with automatic reset, high pressure safety valve, compressor thermal overload protection, fans thermal overload protection, pressure transducer (used to optimize the defrost cycle and the fan speed depending on the ambient conditions), flow switch.

## Versions

### Version P2U

This is a two pipe version that can produce hot water for heating and cold water for cooling. The unit is used with two pipe water based change-over systems. It is not able to produce domestic hot water.

### Version P2S

This is a two pipe version that can, in addition to producing hot water for heating and cold water for cooling, also generate domestic hot water. The controller has dual heating set points (heating and DHW) and can also control a three port diverting valve that directs the DHW to the cylinder. DHW production has priority irrespective of the mode of operation of the unit. The unit is normally used with two pipe water based change-over systems.

### Version P4S

This is a four pipe version that can produce hot water for heating, cold water for cooling and domestic hot water in all operational modes using an independent water circuit. When cooling, DHW generation is by heat recovery. This unit is normally used with two pipe water based change-over systems with the DHW circuit being separate.

### Version P4U

This is a four pipe version that provides a modern approach to four pipe water based systems. Instead of using a boiler and chiller, this unit can generate hot water in one circuit, cold water in the other circuit either individually or simultaneously. When operating in simultaneous mode the heating capacity is equal to the cooling duty plus the power input to the compressors. The operating efficiency in this mode is extremely high. Domestic hot water production for this version is not available.

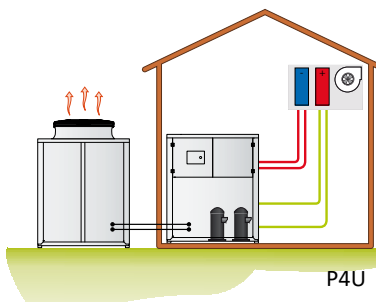
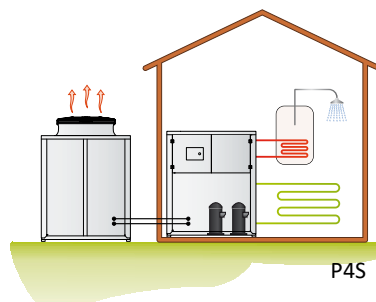
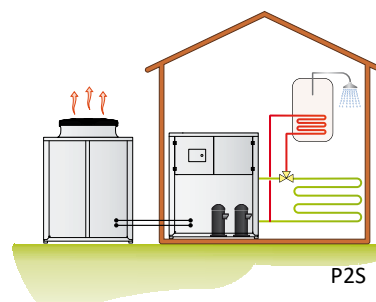
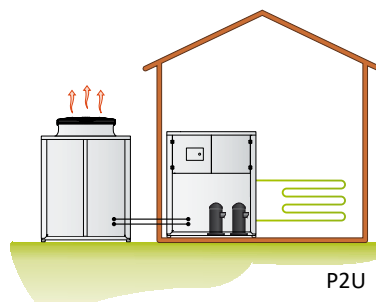

## Noise Reduction

All units are supplied, as standard, with the latest 'Floating Frame' technology that completely isolates the compressors from the main casing, thereby eliminating vibration and noise from this source. The 'Floating Frame' is a special vibration and acoustic damping system that consists of a base plate and acoustic enclosure that houses the compressors. The base plate is separated from the supporting frame of the unit by soft steel springs that have a high damping power. Within the enclosure, the compressors are mounted on rubber shock absorbers on the floating base plate. The enclosure is manufactured from galvanized steel sandwich panels that have a micro-perforated inner skin and a core of 30 mm thick, high density (25 kg/m<sup>3</sup>). The entire arrangement provides a double damping system and acoustic attenuation. The compressor refrigerant pipes are connected to the refrigerant circuit through "anaconda" flexible connections. Flexible connections are also used on the water pipework within the unit. The combination of these systems results in an overall noise reduction in the region of 6-8 dB(A).

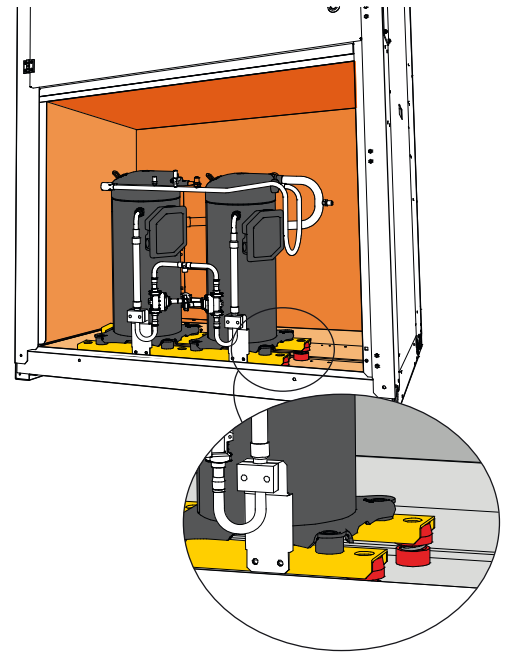

## Operation limits

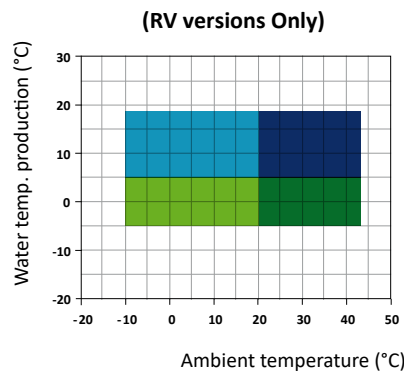
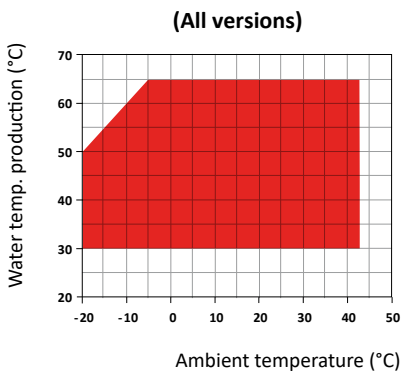

- Heating mode
- Cooling with head pressure control
- Cooling with head pressure control and glycol
- Cooling with head pressure control and glycol
- Cooling with head pressure control and glycol

WZT/NN		252	302	452	502	602	752	852	1002	1202
Main switch		●	●	●	●	●	●	●	●	●
Compressor automatic switch		●	●	●	●	●	●	●	●	●
Flow switch		●	●	●	●	●	●	●	●	●
Evap/cond pressure control by transducer and fan speed control		●	●	●	●	●	●	●	●	●
Fresh air temperature probe for set-point compensation		●	●	●	●	●	●	●	●	●
Specific software for operation priorities		●	●	●	●	●	●	●	●	●
Remote ON/OFF digital input		●	●	●	●	●	●	●	●	●
Summer/Winter digital input		●	●	●	●	●	●	●	●	●
Floating frame technology		●	●	●	●	●	●	●	●	●
Condensate tray with anti-freeze heater (outdoor section)	BRCA	●	●	●	●	●	●	●	●	●
E.C. fans - HE versions	VECE	●	●	●	●	●	●	●	●	●
Cascade control system via RS485	SGRS	○	○	○	○	○	○	○	○	○
Rubber anti-vibration mountings	KAVG	○	○	○	○	○	○	○	○	○
Evaporator antifreeze heater	RAEV2/4	○	○	○	○	○	○	○	○	○
Electronic soft starter	DSSE	○	○	○	○	○	○	○	○	○
Remote control panel	PCRL	○	○	○	○	○	○	○	○	○
Serial interface card RS485	INSE	●	●	●	●	●	●	●	●	●
Electronic thermostatic valve	VTEE	○	○	○	○	○	○	○	○	○

● Standard, ○ Optional, – Not Available.

**WZT - Indoor unit**

Mod.	A(mm)	B(mm)	C(mm)	kg
252	1600	800	1150	510
302	1600	800	1150	515
452	1600	800	1150	535
502	1600	800	1150	560
602	1600	800	1150	580
752	1600	800	1150	585
852	1600	800	1150	590
1002	1600	800	1150	600
1202	1600	800	1150	600

**Matching with outdoor unit**

Mod.
1
2
3
4
4
5
5
6
6

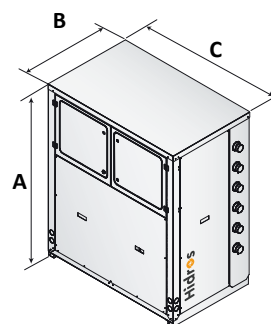

**EVV - Outdoor unit with single heat exchanger and vertical airflow**

Mod.	Fans (n°)	A(mm)	B(mm)	C(mm)	kg
1	2	1680	1615	875	242
2	2	1680	1615	875	263
3	2	1880	2115	1145	310

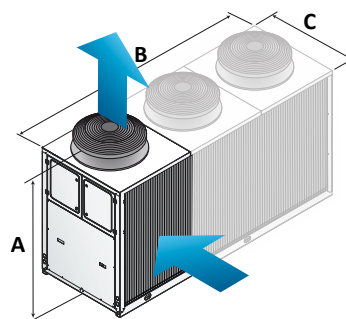

**EVR - Outdoor unit with double heat exchanger and vertical airflow**

Mod.	Fans (n°)	A(mm)	B(mm)	C(mm)	kg
4	2	1880	2115	1145	406
5	2	1880	2115	1145	425
6	3	1880	3115	1145	406

